

- REQUIRED**
- 4x [Screw]
 - H1.5 [Screw]
 - H2 [Screw]

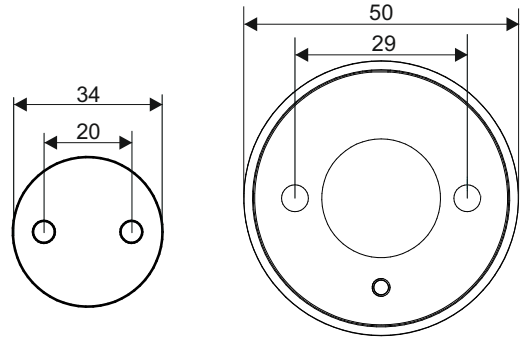

<p>1</p> <p>Diagram showing the luminaire with wires and screws (I, H2, 2x) being prepared.</p>	<p>2</p> <p>Diagram showing the luminaire being mounted to the wall using screws (I, H1.5, 2x).</p>	<p>3</p> <p>Diagram showing the electrical connection to the luminaire using screws (I, II, III, IV). Includes a warning icon: OFF.</p>
<p>4</p> <p>Diagram showing the power cable being connected to the luminaire using screws (I, II, III, H2, 2x). Includes a detail of the terminal block with L, N, and PE markings.</p>	<p>5</p> <p>Diagram showing the luminaire being mounted to the wall using screws (I, II, H1.5, 2x).</p>	
<p>6</p> <p>Źródło światła zastosowane w tej oprawie oświetleniowej powinno być wymieniane wyłącznie przez producenta lub jego przedstawiciela serwisowego, lub podobnie wykwalifikowaną osobę.</p> <p>The light source contained in this luminaire shall only be replaced by the manufacturer or his service agent or a similar qualified person.</p>	<p>Diagram showing the final installation of the luminaire with the CCT Switch. Includes a warning icon: ON.</p>	



Ten produkt zawiera źródła światła o klasach efektywności energetycznej E. This product contains a light sources of energy efficiency class E.

LED
int